



BUKO-S s.r.o.

Průmyslový areál na Baťově, budova č.55, P.O.Box 23
tř. T. Bati 1644, 765 01 Otrokovice 1
Česká republika



BATCHFEEDER G151-1201, G151-901

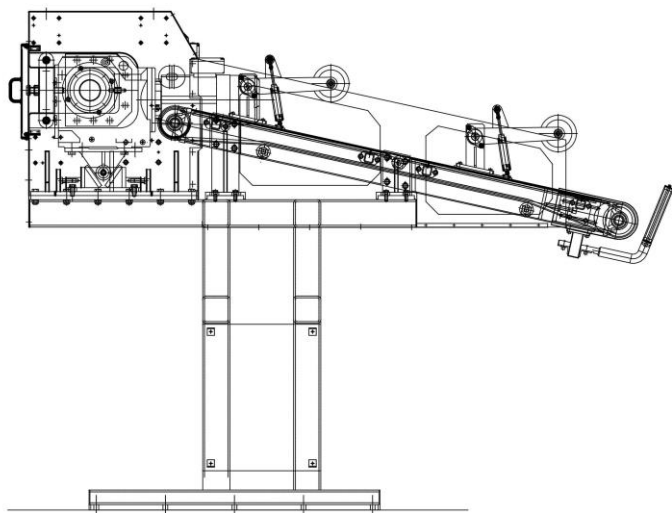

Telefon: +420577663734 Tel./fax: 577663733
+420577663735 Email: buko-s@volny.cz
+420577663732 www.buko-s.cz

Bankovní spojení
KB Otrokovice
č.ú.: 196440570207/0100

IČO: 63477548
DIČ: CZ63477548
OR: odd.C.vložka 20569

MAIN DESCRIPTION

Batchfeeder is designed for rubber and plastic industry. It is used to feed compound into the mixers or two-roll mills. It is able to cut rubber sheets into pieces or wig wag sheets from **1 to 3 palettes – total thickness is max. 36mm**. The compound is steady on the feeding conveyor by pressed wheels.

The rotor is powered by AC gear motor 15 kW includes brake and constant speed 40 or 47 rpm. Feeding conveyor is powered by AC gear motor 3 kW includes brake, frequency controlled. The belt speed is 2 – 30 m/min.

The belt centering is manage by tightening device plus V-belt glued on the bottom part of the belt and grooves on powered and turn back cylinders.

In case of installation of two Batchfeeders next to each other are main drives outside for better maintenance access. Rotating knife is exchangeable and simple replacement is commonplace.

MECHANICAL DESCRIPTION

The Batchfeeder consists of the feeding conveyor, mounted on a rigid frame with pressed wheels and cutting part with fixed knife and rotating knife. The frame is equipped by holes for mounting the machine to the floor. Pressed wheels can be lifted up or pressed down by pneumatic cylinders. The cutting part consists of one stationary knife and one rotation knife mounted on the rotating shaft under and angle. The rotor shaft is equipped with roller bearings with minimum clearance. The clearance between fixed and rotating knives is adjusted by two adjustment screws.

TECHNICAL DATA:

TYPE:	G151-1201	G151-901
Maximum sheet width	1200 mm	900 mm
Maximum thickness of cut belt or its layer	36 mm	36 mm
Conveyor belt width/lenght	1300/5580 mm	980/5580 mm
Range of quiding rolls	955 - 1325 mm	620 - 930 mm
Width of the pressured pulleys	890 mm	850 mm
Range of ghe conveyor belt speed	2,2 - 27,5 m/min.	2,2 - 27,5 m/min.
Size range of cut strips of rubber compound	37 - 460 mm	37 - 460 mm
Rotating knife speed	40 or 47 rpm.	40 or 47 rpm.

MAIN DIMENSIONS:		
length	3658 mm	3073 mm
width	2408 mm	2091 mm
height	2725 mm	2725 mm
Total weight	4950 kgs	4450 kgs